

INSTALLATION INSTRUCTIONS

108124 Syclone/Typhoon to XFI Adapter

This adapter is designed to connect the XFI ECU to the Syclone/Typhoon engine wiring harness in "Plug-And-Play" fashion. The adapter accesses the three ECU connectors; two black and one green, which are found on the OEM engine wiring harness.

The adapter converts the factory "batch" firing injectors to sequential injection by replacing the factory injector harness with a specially-built sequential harness. The interface cable that goes between the "D" XFI connector and sequential injector harness includes a sealed relay and ground terminal along with a positive feeder which will attach to a 12 volt battery source. The feeder is fuselink-protected and has a 10mm terminal which can fit directly onto the positive battery post.

When setting up your XFI for the Sy/Ty, use a Grand National 3.8 startup program, and change the Cu. In. to read 274 CID (4.3L). With sequential injectors, you can use any size injector suitable for your engine build, as the injector drivers can handle the current requirements. Be sure to set your program to "Sequential" mode.

When installing this adapter, be sure to attach the ground ring to a suitable ground on the vehicle chassis. You will need to install an ESC module for knock control. Use the FAST-supplied extension when installing the wideband O2 sensor. The extension will plug into the gray connector. You must also use the FAST-supplied extension to connect your PC to this adapter.

Be sure to connect the small plug labeled "To 'D' Injector Harness" to its mating connector.

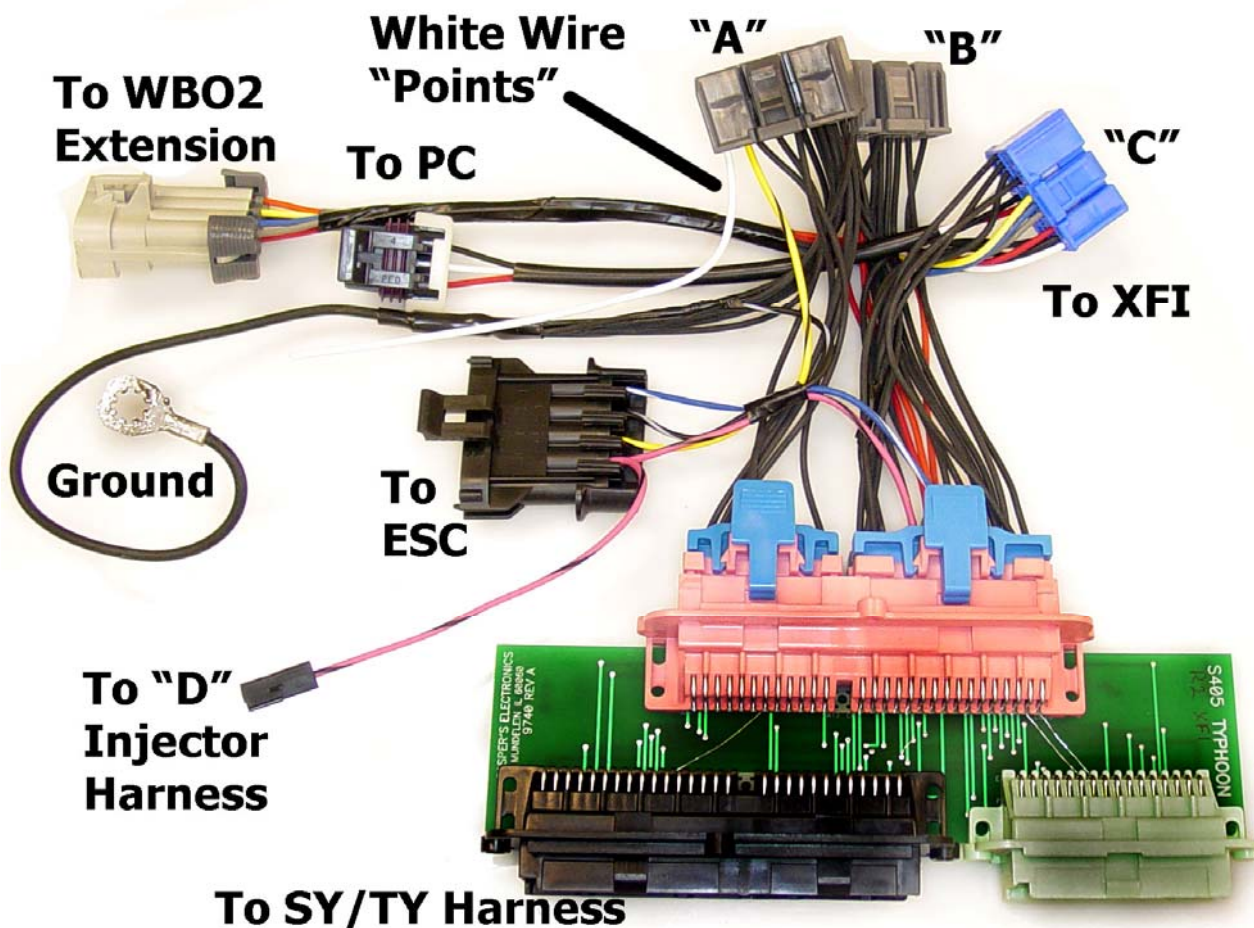

NOTE: There is no provision for fuel pump control as it is assumed you are using a separate "stand-alone" relay system to run your fuel pump.

The injector harness shown here replaces the factory injector harness. Position this harness onto the injectors and attach its connector to the Injector Interface cable provided in the kit. You will need to mount the relay to a suitable space behind the engine. Attach the positive feed to the battery positive post and feed the harness thru the firewall to the location of the adapter box. Once the Interface Cable is in place, insert the "D" connector into the XFI receptacle, and be sure to attach the grounding ring securely to the chassis. Attach the small one-wire connector to its mating connector; this wire is the injector relay feed.

The adapter also is fitted with a white "Points" wire intended to be used when interfacing the MSD box if used in your application.

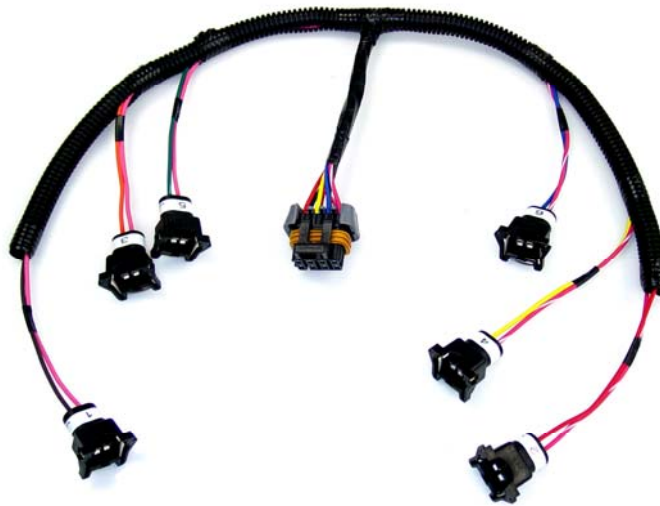

Sequential Injector Feed Harness

